

**NOTE**

*Some components are difficult to remove from the circuit board due to a bend placed in the component leads during machine insertion. To make removal of machine-inserted components easier, straighten the component leads on the reverse side of the circuit board.*

2. When removing a multipin component, especially an IC, do not heat adjacent pins consecutively. Apply heat to the pins at alternate sides and ends of the IC as solder is removed. Allow a moment for the circuit board to cool before proceeding to the next pin.

**CAUTION**

*Excessive heat can cause the etched circuit conductors to separate from the circuit board. Never allow the solder extractor tip to remain at one place on the board for more than three seconds. Solder wick, spring-actuated or squeeze-bulb solder suckers, and heat blocks (for desoldering multipin components) must not be used. Damage caused by poor soldering techniques can void the instrument warranty.*

3. Bend the leads of the replacement component to fit the holes in the circuit board. If the component is replaced while the board is installed in the instrument, cut the leads so they protrude only a small amount through the reverse side of the circuit board. Excess lead length may cause shorting to other conductive parts.

4. Insert the leads into the holes of the board so that the replacement component is positioned the same as the original component. Most components should be firmly seated against the circuit board.

5. Touch the soldering iron to the connection and apply enough solder to make a firm solder joint. Do not move the component while the solder hardens.

6. Cut off any excess lead protruding through the circuit board (if not clipped to the correct length in Step 3).

7. Clean the area around the solder connection with an approved flux-removing solvent. Be careful not to remove any of the printed information from the circuit board.

**REMOVAL AND REPLACEMENT PROCEDURE**

Read these instructions completely before attempting any corrective maintenance.

**WARNING**

*To avoid electric shock, disconnect the instrument from the ac power source before removing or replacing any component or assembly.*

The exploded view drawing in the "Replaceable Mechanical Parts" list at the rear of this manual may be helpful during the removal and installation of individual components or subassemblies. Figure 6-2 illustrates the locations of the circuit boards referred to in this procedure. Individual circuit boards are illustrated in the "Diagrams" section of this manual; those illustrations are useful in location of the components referred to in this procedure.

As a further aid in component location, this procedure specifies the location of most of the components to be disconnected. The component side of a circuit board is referred to as the "top" side of the board; the edge nearest the Front Panel is the front edge. The remaining sides and edges follow from this orientation.

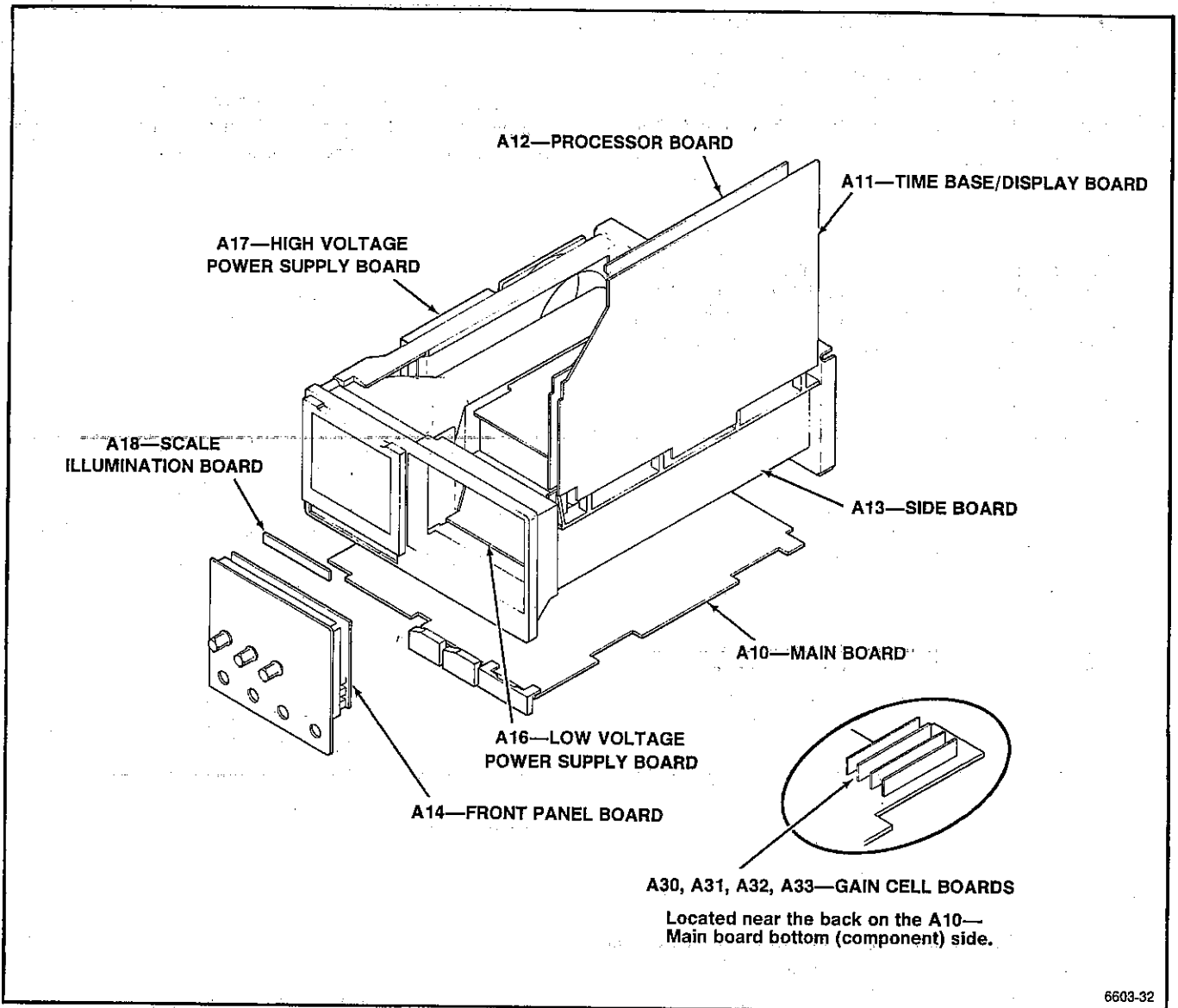

6603-32

Figure 6-2. Circuit Board Location.

## 1. Cabinet Removal

- a. Disconnect the power cord from any ac power source.
- b. Disconnect the power cord from its receptacle at the instrument's Rear panel.
- c. Grasp the power cord plug (female end), rotate the power cord retainer 1/4 turn, and pull it to remove the cord from the Rear panel.
- d. Grasp the handle hubs (at right and left side of the instrument) and pull outward. Rotate the hubs to position the front of the handle away from the front of the instrument.
- e. Install the protective Front cover over the Front panel. Push on the cover to lock the cover's side tabs around the Front panel's trim band.
- f. Set the instrument so it rests on the Front cover.
- g. Remove the four screws inside the four rear feet at the instrument's back panel.

### WARNING

*Dangerous potentials exist at several points throughout this instrument. If it is operated with the cabinet removed, do not touch exposed connections or components. Some transistors may have elevated case voltages. Disconnect the ac power source from the instrument and verify that the line-rectifier filter capacitors have discharged before cleaning the instrument or replacing parts (see label on the Low Voltage Power Supply cover).*

- h. Grasp the handle hubs (at right and left sides of the instrument) and pull outward. While holding the hubs outward, pull straight up from the rear of the cabinet to remove the cabinet from the instrument.

Reverse parts a through h to install the cabinet.

### WARNING

*The line-rectifier capacitors normally retain a charge for several minutes after the instrument is powered off and can remain charged for a longer period if a bleeder resistor or other power supply problem occurs. Before beginning any cleaning or work on the internal circuitry of the instrument, discharge the capacitors by connecting a shorting strap in series with a 1 k $\Omega$ , 5 watt resistor across the capacitors. Connect one end of the shorting strap/resistor combination to upper-most terminal of S1020 (the terminal connected through a wire to W310). Connect the other end to pin 11 of T117 (the pin protruding from the side of the transformer, near its right-rear corner). Measure across those two connections with a voltmeter to ensure the capacitors are discharged.*

## 2. Timebase/Display Board Removal

- a. Perform Step 1 to remove the cabinet.
- b. Set the instrument on a flat, smooth surface, with its underside facing down and the Front panel facing forward.
- c. Disconnect the ribbon-cable connector from J100 of the Timebase/Display board. J100 is located at the right-front corner of the Timebase/Display board.
- d. Disconnect the ribbon cable connector at J141 of the Main board. J141 is located at the lower right-rear corner of the instrument.
- e. Disconnect the ribbon cable connector at J121 of the Timebase/Display board. J121 is located at the right-rear corner of the board, under the ribbon cable disconnected in part d.
- f. Disconnect P117 and P148 from J117 and J148. J117 and J148 are located on the Timebase/Display board, at the right-rear corner and center-rear edge, respectively.
- g. Remove the three mounting screws securing the Timebase/Display board to the Center chassis and Power Supply.

h. Using a 7/32 inch nutdriver, rotate the two black plastic retaining latches counterclockwise 1/4 turn to unlock them. The two retaining latches are located near the left-front and left-rear corners of the Timebase/Display board.

i. Grasp the left edge of the Timebase/Display board and rotate it (and the Top chassis) upward about 45 degrees. While supporting the Top chassis, disconnect the ribbon cable connector at J131 (left-front corner of the Timebase/Display board) and the flex cable at J125 (right-rear corner of the Processor board on the underside of the Top chassis).

j. Continue to rotate the Top chassis until it is at a 90 degree angle to the top of the instrument.

k. Rotate the black retaining latch (center-left edge of the Timebase/Display board) 1/4 turn counterclockwise to release the board from the Top chassis.

l. Grasp the left edge of the board and pull it slightly away from the Top chassis until it clears the head of the retaining latch unlocked in part k. Pull up on the board until the right edge of the board slips out of the four channel notches on the Top chassis.

Reverse parts a through l to install the board to the Top chassis and to secure the Top chassis to the Center chassis. Take care to fit the right edge of the board to the four channel notches when installing the board on the Top chassis.

### 3. Processor Board Removal

a. Perform Step 1 to remove the cabinet.

b. Set the instrument on a flat, smooth surface, with its underside facing down and the Front panel facing forward.

c. Remove the three mounting screws securing the Timebase/Display board to the Center chassis and Power Supply.

d. Using a 7/32 inch nutdriver, rotate the two black retaining latches counterclockwise 1/4 turn to unlock them. The two retaining latches are located near the left-front and left-rear corners of the Timebase/Display board.

e. Grasp the left edge of the Timebase/Display board and rotate it (and the Top chassis) upward about 45 degrees. While supporting the Top chassis, disconnect the ribbon cable connector at J131 (left-front corner of the Timebase/Display board) and the flex cable at J125 (right rear corner of the Processor board on the underside of the Top chassis).

f. Continue to rotate the Top chassis until it is at a 180 degree angle to the top of the instrument. The top of the Processor board is now exposed.

g. Disconnect the ribbon-cable connector from J103 and the flex cable connector from J207 of the Processor board. J103 and J207 are located at the left-front corner of the board.

h. Disconnect the ribbon cable connector at J123 of the Processor board (instruments with Option 05 installed only). J123 is located at the rear quarter section of the board near the center.

i. Disconnect the ribbon cable connectors at J181 and J120 of the Processor board. J181 and J120 are located at the left rear corner of the board.

j. Rotate the black retaining latch (center-right edge of the Processor board) 1/4 turn counterclockwise to release the board from the Top chassis.

k. Grasp the right edge of the board and pull it slightly away from the Top chassis until it clears the head of the retaining latch unlocked in part j. Pull up on the board until the left edge of the board slips out of the four channel notches on the Top chassis.

Reverse parts a through k to install the board on the Top chassis and to secure the Top chassis to the Center chassis. Take care to fit the edge of the board to the four channel notches when installing it on the Top chassis.

### 4. Front Panel Board Removal

a. Perform Step 1 to remove the cabinet from the instrument.

b. Set the instrument on a flat, smooth surface, with its underside facing down and the Front panel facing forward.

c. Pull straight out on the INTENSITY control knob to remove it from its shaft.

d. Using a small, flat-bladed screwdriver, gently pry loose and remove the top trim cover.

e. Remove the four screws exposed by part d.

f. Turn the instrument over to expose the bottom of the trim ring and remove the two screws securing the front feet to the instrument. Remove the feet from the trim ring.

g. Remove the two remaining screws securing the trim ring.

h. Grasp the edges of the trim ring and pull forward to remove it from the Front casting.

i. Turn the instrument over so its top side is up.

j. Remove the three mounting screws securing the Timebase/Display board to the Center chassis.

k. Using a 7/32 inch nutdriver, rotate the two black retaining latches counterclockwise 1/4 turn to unlock them. The two retaining latches are located near the left-front and left-rear corners of the Timebase/Display board.

l. Grasp the left edge of the Timebase/Display board and rotate it (and the Top chassis) upward about 45 degrees. While supporting the Top chassis, disconnect the flex cable at J125 (right-rear corner of the Processor board on the underside of the Top chassis).

m. Continue to rotate the Top chassis until it is at a 180 degree angle to the top of the instrument.

n. Disconnect the ribbon cable connector from J166 on the Low Voltage Power Supply board and push it towards the rear of the instrument. J166 is located at the left-front section of the board near the front corner of the Center chassis.

o. Disconnect the ribbon cable connector from J150 at the front of the Side board.

p. Remove the anode lead from its retainer and dress it away from the lower square hole in the Main chassis. Take care not to separate the male end of that lead from the female end.

q. Disconnect the ribbon cable connector from J152 of the Main board. J152 is located in front of the High Voltage shield, at the lower left side of the instrument.

r. Carefully route the connectors disconnected in parts o and q to the inside of the instrument.

s. Gently push the backside of the Front Panel Control assembly until it is removed from the Front casting.

t. To remove the Front Panel Control board from the Front panel, perform the following subparts:

(1) Using a 1/16 inch allen wrench, remove the CH 1 and CH 2 VOLTS/DIV control knobs, as well as the A and B SEC/DIV control knob.

(2) Pull straight out on the remaining five control knobs to remove them from their shafts.

(3) Turn the Front panel face down and remove the four mounting screws from the Front Panel Control board. Separate the Front panel from the board.

Reverse parts a through t to assemble the Front panel assembly and install it on the instrument. Take care to align the GPIB Status indicators to their holes in the trim ring when installing that band.

## 5. Main Board and Gain-Cell Board Removal

a. Perform Step 1 to remove the cabinet from the instrument.

b. Perform parts a through h of Step 4 to remove the Front Panel trim ring.

c. Pull the Front Panel assembly forward until it is clear of the Front casting and the face of the Front casting is accessible (it is not necessary to disconnect the cables connecting the assembly to the main instrument).

d. Remove the six screws securing the Main board to the Front casting. The screws are located on the face of the casting and are adjacent to the four BNC connectors.

e. Disconnect the two flex cable connectors at J104 and J108, and the ribbon cable connector at J105. J104, J105, and J108 are located near the right-front corner of the board.

f. Disconnect the three ribbon cable connectors from J111, J113 (TV Trigger option only), and J141 at the left edge of the board.

g. Disconnect the cable connector from J107, located near the right-rear corner of the board, and from J106, located near center-front edge of the board.

h. Remove the screw securing the end of the Power switch's extension shaft to the Front casting.

i. Grasp the large extension shaft near where it joins to the small shaft of the power switch and pull it upwards from the Main board to disconnect it. Lift up and back (towards the rear of the instrument) to remove the extension shaft from the Front casting.

#### NOTE

*When installing the extension shaft to the Power switch, push the small shaft to put the switch in the IN position. Insert the shaft into the Front casting, align the extension shaft to the small shaft, and push the button end of the switch until the two shafts are coupled.*

j. Using a 7/32 inch nutdriver, rotate the seven black retaining latches 1/4 turn counterclockwise to release them.

k. Disconnect the flex cable connector from J114 and the two retaining latches. J114 is located in left-rear corner of the board.

l. Remove the two mounting screws securing the Main board to Main chassis.

m. Lift the board up from the instrument and back from the Front casting to complete the board removal.

n. **GAIN CELL BOARD REMOVAL:** If one (or more) of the four Gain-Cell boards (mounted on right-rear corner of the Main board) is to be removed, turn the Main board over. Then desolder the 13 pins (two groups—one of five pins, the other of eight) that connect the Gain-Cell board to the main board, working from the bottom of the board. When the pins are free the board can be removed. To reinstall, remount and resolder.

Reverse parts a through m to install the Main board.

## 6. Side Board Removal

a. Perform Step 1 to remove the cabinet from the instrument.

b. Set the instrument on a flat, smooth surface with the Side board facing up and the Front panel facing forward.

c. Disconnect the ribbon cable connectors from J111 and J141 of the Main board.

d. Disconnect the ribbon cable connectors from J100 of the Timebase/Display board and J103 of the Processor board. The two connectors are attached to the same ribbon cable.

e. Disconnect the ribbon cable connectors from J121 of the Timebase/Display board and J120 of the Processor board. The two connectors are attached to the same ribbon cable.

f. Disconnect the ribbon cable connector from J150 of the Side board.

g. Perform parts j through l of Step 4 to access the inside of the instrument.

h. Disconnect the ribbon cable connector from J102 at the right front corner of the Low Voltage Power Supply board and route the cable to the outside of the instrument.

i. Rotate the Top chassis back to the normal (installed) position. Using a 7/32 inch nutdriver, rotate the two retaining latches 1/4 turn clockwise to temporarily secure it to the instrument.

j. Rotate the black retaining latch (near the front of the Side board) 1/4 turn counterclockwise to unlock it.

k. Remove the mounting screw (center of the Side board) securing the Side board to the Main chassis.

l. Lift the front of the Side board up until it clears the retaining latch and then pull the board forward, until it clears the channel notch at its rear edge, to complete the removal.

Reverse parts a through l to install the Side board in the instrument. Take care to fit the rear edge of the board to the channel notch when reinstalling to the chassis.

## 7. High Voltage Power Supply Board Removal

a. Perform Step 1 to remove the cabinet from the instrument.

b. Set the instrument on a flat, smooth surface with the High Voltage Supply board facing up and the Front panel facing forward.

### WARNING

*The CRT anode lead may retain a high-voltage charge after the instrument is powered off. To avoid electrical shock, ground the CRT anode lead to the metal chassis after disconnecting the plug. Reconnect and disconnect the anode-lead plug several times, grounding the anode lead to chassis ground each time it is disconnected to fully dissipate the charge.*

c. Remove the anode lead from the retaining hook that secures it to the Main chassis.

d. Disconnect the CRT lead (male end) from the High Voltage Module lead.

e. Remove the single screw securing the High Voltage Power Supply and lift the High Voltage shield off.

### WARNING

*The five mounting posts on the side of the High Voltage module (U565) may retain a high-voltage charge after the instrument is powered off. To avoid electrical shock, discharge these posts to the metal chassis through an appropriate shorting strap.*

f. Discharge the five posts on the side of the High Voltage module to the metal chassis.

g. Disconnect the cable connectors from J172 and J173, located at the front edge of the board, and from J162 and J176, located the rear edge of the board.

h. Disconnect the remaining ribbon connector from J105 on the Main board.

i. Pry outward on either one of two retaining latches securing the fan on its mounting posts. As the latch clears the edge of the fan, pull the fan outward and away from the instrument to remove. The latches are located at opposite corners; one at the bottom corner nearest the rear, the other at the top corner nearest the front, of the instrument.

j. Perform parts j through l of Step 4 to access the inside of the instrument.

k. Disconnect the crt connector from the back of the crt.

l. Rotate the two black retaining latches (near the front- and rear-left corners of the High Voltage Power Supply board) 1/4 turn counterclockwise to unlock them.

m. While holding its nut (located between the crt shield and the adjacent Main chassis) stationary, remove the mounting post (near the center of the board) securing the High Voltage Power Supply board to the Main chassis.

n. Lift the left edge of the board up to clear the retaining latches. Pull the board to the left, until its right edge clears the two channel notches, to complete the removal.

Reverse parts a through n to install the High Voltage Power Supply board. Take care to fit the left edge of the board to the channel notches when reinstalling the board.

## 8. Low Voltage Power Supply Assembly Removal

a. Perform Step 1 to remove the cabinet from the instrument.

b. Disconnect the ribbon cable connector at J113 of the Main board to access the mounting screw at the center of the Side board. Remove that screw.

c. Remove the mounting screw at the center of the Side board. Note that for instruments with Option 05 installed, it is necessary to disconnect the ribbon cable connector at J113 of the Main board to access the mounting screw.

d. Disconnect the ribbon cable connector at J148 of the Timebase/Display board.

e. Perform parts j through l of Step 4 to access the inside of the instrument.

f. Disconnect the ribbon cable connectors at J102 (right front corner of the Low Voltage Power Supply board) and J166 (left front corner of the same board).

g. Disconnect the flex cable connector from J207 at the left front corner of the Processor board.

h. Remove the six screws and two extension posts securing the Low Voltage Power Supply cover (hereafter referred to as "the cover") to the Low Voltage Power Supply bracket.

i. Remove the screw securing the cover to the Center chassis.

j. Remove the two screws securing the cover to the Rear chassis. One screw is located immediately below the GPIB Connector, the other immediately below the PLOTTER X OUTPUT BNC.

k. Lift the cover off the Low Voltage Power Supply bracket to remove.

l. Disconnect the four cable connectors from P30, P60, P70, and P80 (located near the rear of the Low Voltage Power Supply board). Note the color coding of the cables to guide in reconnection of same.

m. Using a 7/32 inch nutdriver, rotate the two black retaining latches (near the left and right front corners of the Low Voltage Power Supply board) 1/4 turn counter-clockwise to unlock them. Repeat for the two latches located near the middle of the right and left edges of the board.

n. Remove the mounting screw securing the Low Voltage Power Supply assembly to the Main chassis. The screw is located near the right-front corner of the board.

o. Carefully route the disconnected cables away from the top side of the Low Voltage Power Supply assembly.

p. Grasp the front of the Low Voltage Power Supply bracket and lift up until the Low Voltage Power Supply board is clear of the retaining latches unlocked in part m.

q. Pull the board towards the front of the instrument (until its rear edge clears the two channel notches) while lifting upwards to complete the removal of the assembly.

Reverse parts a through q to assemble the Low Voltage Power Supply assembly and secure it to the instrument. Take care to fit the board to the channel notches when reinstalling the board.

## 9. Cathode Ray Tube Removal

### WARNING

*Use care when handling a crt. Breakage of the crt may cause high-velocity scattering of glass fragments (implosion). Protective clothing and safety glasses (preferably a full-face shield) should be worn. Avoid striking the crt on any object which may cause it to crack or implode. When storing a crt, place it in a protective carton or set it face down on a smooth surface in a protected location. When stored face down, it should be placed on a soft, nonabrasive surface to prevent the crt face plate from being scratched.*

a. Perform Step 1 to remove the cabinet from the instrument.

b. Perform parts c through i of Step 4 to remove the trim band from the instrument.

c. Remove the implosion shield from the crt faceplate.

### WARNING

*The crt anode lead may retain a high-voltage charge after the instrument is powered off. To avoid electrical shock, ground the crt anode lead to the metal chassis after disconnecting the plug. Reconnect and disconnect the anode-load plug several times, grounding the anode lead to chassis ground each time it is disconnected to fully dissipate the charge.*

d. Remove the anode lead from the retaining hook that secures it to the Main chassis.



e. Disconnect the crt anode lead (male end) from the high-voltage module lead. Discharge the crt anode lead by grounding its tip to the metal chassis.

f. Disconnect the cable from J172 at the right-front corner of the High Voltage Power Supply board.

g. Perform parts j through l of Step 4 to access the inside of the instrument.

h. Disconnect the crt connector from the back of the crt.

i. Disconnect the single cable from the crt (accessed through a hole in the top of the crt shield).

j. Disconnect the ribbon cable at J148 of the Timebase/Display board.

k. Disconnect the flex cable at J104 of the Main board.

l. Remove the eight screws (two at each corner) securing the crt frame to the Front casting.

m. Remove the crt frame from the Front casting. Guide the flex cable disconnected in part k through its slot in the Front casting while removing the crt frame.

n. Grasp the face of the crt and pull it forward, while guiding the crt anode lead and the other cable (disconnected in part f) through their holes in the crt shield. It may be necessary to reposition the ribbon cable (disconnected in part j) as the removal of the crt is completed.

Reverse parts a through n to install the crt. When installing the crt frame (removed in part m) to the casting, refer to Figure 6-3 for the method of installation.

## 10. Menu Switch Removal

a. Perform Step 1 to remove the cabinet from the instrument.

b. Disconnect the flex cable at J104 of the Main board.

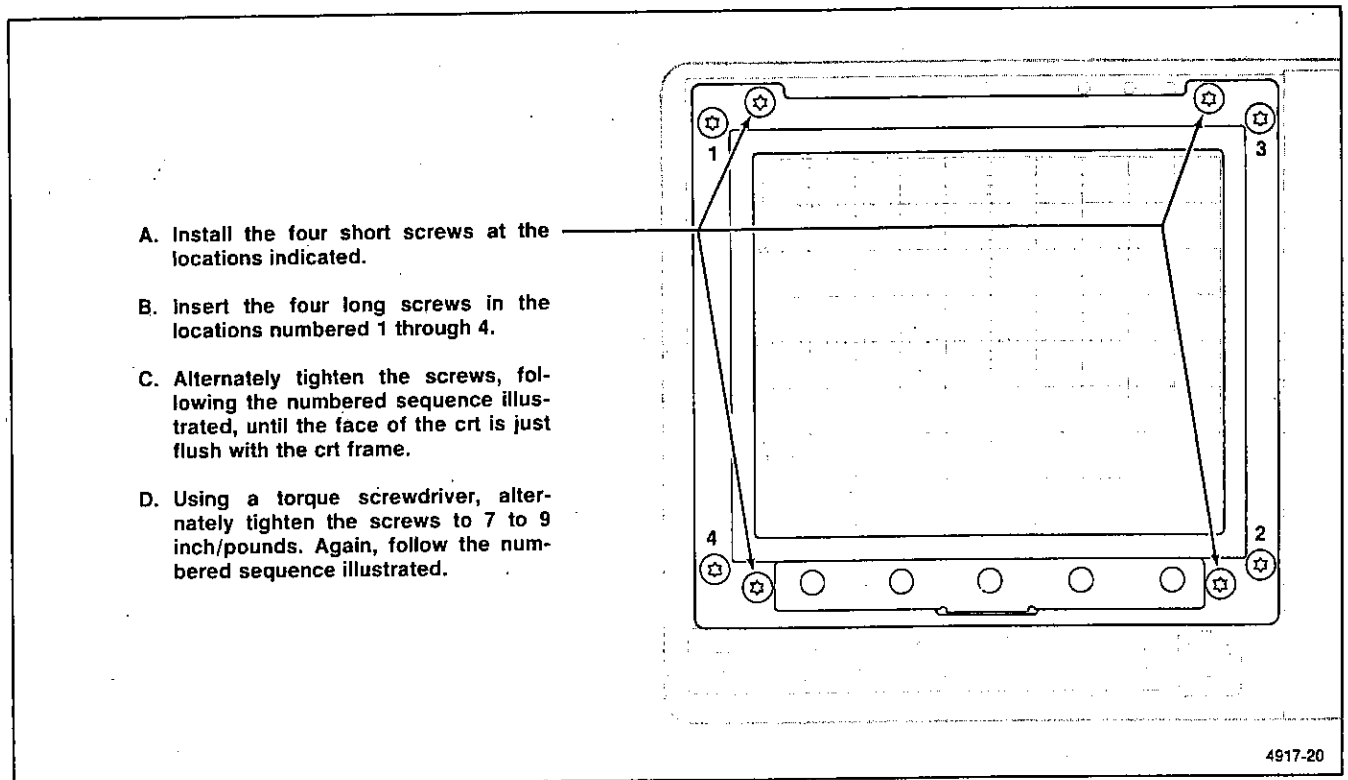

Figure 6-3. Installation sequence for installing the crt frame screws.

c. Perform parts c through i of Step 4 to remove the trim band from the instrument.

d. Perform parts k through m of Step 9 to remove the crt frame from the instrument.

e. Carefully pull the adhesive-backed switch from the front of the crt frame.

f. Pull the switch through the hole in the crt frame to complete the removal.

Reverse parts a through e to install the Menu switch to the crt frame and the frame to the instrument. Use care to align the switch to the locating studs on the crt frame when pressing the switch back on the frame.

### 11. Scale Illumination Board Removal

a. Perform parts a through e of Step 10.

b. Disconnect the Scale Illumination board cable from J106 (located near the front edge of the Main board).

c. Remove the Scale Illumination board and the attached light reflector while guiding the cable (disconnected in part b) through its hole in the Front casting.

d. Separate the Scale Illumination board from the light reflector to complete the disassembly.

Reverse parts a through d to install the Scale Illumination board to the instrument.

### 12. Attenuator Removal Procedure

a. Perform Step 1 to remove the cabinet from the instrument.

b. Perform parts b through s of Step 4 to access the inside of the instrument. Skip parts n, p, and q. When performing part r of Step 4, route the cable disconnected in part o.

c. Insert the tip of a short screwdriver through the large slot in the front casting (above and right of the associated input BNC connector). Remove the screw securing the front of the Attenuator to the Main board.

d. Insert the tip of a screwdriver through the hole in the Low Voltage Power Supply board that is directly above the Attenuator to be removed. Remove the screw securing the rear of the Attenuator to the Main Board.

e. Rotate the Timebase/Display board to its mounting position and temporarily secure it by rotating the two black retaining lugs 1/2 turn clockwise to lock them. The two retaining latches are located near the left-front and left-rear corners of the Timebase/Display board.

f. Remove the two screws securing the rear Attenuator shield to the heatsink. Remove the small shield.

g. Unsolder the two Attenuator output leads from the variable-capacitor lead and the resistor-capacitor pair lead exposed in part f.

h. Unplug the multipin connector from the Main board (at P147 for the CH 1 and P146 for the CH 2 Attenuator).

i. Remove the two screws (one is immediately lower left and the other upper right of the associated input BNC connector) securing the Attenuators to the front casting.

j. Remove the two screws securing the small bar to the bottom of the front casting.

k. Grasp the front end of the Attenuator assembly by its BNC connector and the rear end by the rear edge of the Attenuator shield.

l. Gently lift the Attenuator straight up from the Main board until the Attenuator pins clear their Main board plugs underneath the Attenuator assembly. Lift the rear of the Attenuator assembly up and towards the rear of the instrument until the Attenuator clears the braided shield cable mounted in the front casting.

Reverse parts b through l to reinstall the Attenuator. When performing part b, reverse parts b through s of Step 4 to reinstall the front panel and secure the Timebase/Display board and Front Panel assembly to the instrument.